



KG REDDY
College of Engineering
& Technology
AN AUTONOMOUS INSTITUTION



Strength of Materials Lab

LABORATORY MANUAL

Prepared By: Mr M Rathna Chary, Assistant Professor

**Department of Civil
Engineering**

Institute Vision

To become an institution which is internationally recognized for its holistic approach to engineering, innovative teaching and learning culture, research and entrepreneurial ecosystem, and sustainable social impact in the community.

Institute Mission

- To offer undergraduate and post-graduate programs which are supported through industry relevant curriculum and innovative teaching and learning processes that would help students succeed in their professional careers.
- To provide faculty and students with an ecosystem that fosters innovation, research, entrepreneurship, and international exposure through strategic partnerships with government organizations and collaboration with industries.
- To provide holistic learning environment to students which will contribute to their personal and professional growth and enable them to become leaders in their respective fields.
- To contribute to the development of the region by using our technological expertise to work with nearby communities and support them in their social and economic development

Department Vision

To be recognized for excellence in teaching, innovation, and research aimed towards betterment of society through sustainable infrastructural development.

Department Mission

- To integrate innovative teaching and learning practices that will enable students to build technical competence for working in civil engineering industries.
- To encourage innovation, research, and entrepreneurship among faculty and students that will lead to sustainable development.
- To become self-sustainable through strategic collaborations with industries and nearby communities focused on consultancy services.

Program Educational Objectives

- **PEO1:** Graduates will be able to work in multidisciplinary teams focused on development of infrastructure, design, sustainability, construction management and all the other related fields of Civil Engineering.
- **PEO2:** Graduates will be professionally competent through their ability to use modern civil engineering tools and manage projects in leadership positions.
- **PEO3:** Graduates will transform into change makers who will work towards societal development and advocate for equity, social justice, and sustainable development.

Program Outcomes

PO 1: Engineering Knowledge: Apply knowledge of mathematics, natural science, computing, engineering fundamentals and an engineering specialization as specified in WK1 to WK4 respectively to develop to the solution of complex engineering problems.

PO 2: Problem Analysis: Identify, formulate, review research literature and analyze complex engineering problems reaching substantiated conclusions with consideration for sustainable development. (WK1, WK2)

PO 3: Design/Development of Solutions: Design creative solutions for complex engineering problems and design/develop systems/components/processes to meet identified needs with consideration for the public health and safety, whole-life cost, net zero carbon, culture, society and environment as required. (WK5)

PO 4: Conduct Investigations of Complex Problems: Conduct investigations of complex engineering problems using research-based knowledge including design of experiments, modelling, analysis & interpretation of data to provide valid conclusions. (WK8).

PO 5: Engineering Tool Usage: Create, select and apply appropriate techniques, resources and modern engineering & IT tools, including prediction and modelling, recognizing their limitations to solve complex engineering problems. (WK2 & WK6)

PO 6: The Engineer and The World: Analyze and evaluate societal and environmental aspects while solving complex engineering problems for an appeal of sustainability, with reference to economy, health, safety, legal framework, culture and environment. (WK1, WK5, and WK7).

PO 7: Ethics: Apply ethical principles and commit to professional ethics, human values, diversity and inclusion, adhere to national & international laws (WK9)

PO 8: Individual and team work: Function effectively as an individual, and as a member or leader in diverse teams, and in multidisciplinary settings.

PO 9: Communication: Communicate effectively and inclusively within the engineering community and society at large, such as being able to comprehend and write effective reports and design documentation, make effective presentations considering cultural, language, and learning differences

PO 10: Project Management and Finance: Apply knowledge and understanding of engineering management principles and economic decision-making and apply these to one's own work, as a member and leader in a team, and to manage projects and in multidisciplinary environments.

PO 11: Life-Long Learning: Recognize the need for, and have the preparation and ability for i) independent and life-long learning ii) adaptability to new and emerging technologies and iii) critical thinking in the broadest context of technological change. (WK8)

Program Specific Outcomes

- **PSO1:** Graduates will be able to plan, analyze, design safe and sustainable green infrastructure.
- **PSO2:** Graduates will be able to utilize the latest software tools for modeling and simulation in the field of civil engineering.
- **PSO3:** Graduates will be able to work in multidisciplinary teams to design, develop and promote smart construction related.

Course Objectives: The course will help students to

1. Conduct the Tension test, Compression test on various materials.
2. Conduct the Shear test, bending test on determinate beams.
3. Conduct the Compression test on spring and Hardness test using various machines.
4. Conduct the Torsion test, Impact test on various materials.
5. Ensure a variety of established material testing procedures and techniques.

Course Outcomes: Upon completion of this course, the students will be able to

- CO1: Determine the yield stress, ultimate tensile stress, percentage elongation of steel, compressive Strength of brick and concrete.
- CO2: Determine the ultimate shear stress, modulus of elasticity of steel.
- CO3: Determine the stiffness of the close coiled helical spring and hardness number of mild steels, brass, copper and aluminum.
- CO4: Determine the modulus of rigidity and impact strength of steel.
- CO5: Write a technical laboratory report.

Department of Civil Engineering

Strength of Materials Lab

Course Code: KG25ACE229

B. Tech. II Year I - Semester

LIST OF EXPERIMENTS:

LIST OF EXPERIMENTS

1. Tension test
2. Bending test on (Steel / Wood) Cantilever beam.
3. Bending test on simple support beam.
4. Torsion test
5. Hardness test
6. Spring test
7. Compression test on wood or concrete
8. Impact test
9. Shear test
10. Verification of Maxwell's Reciprocal theorem on beams.
11. Use of electrical resistance strain gauges
12. Continuous beam – deflection test

Text Books:

1. Strength of Materials by R.K. Bansal, Lakshmi Publications House Pvt. Ltd.
2. A text book of Strength of Materials by R.S. Khurmi, S. Chand Publishing

MANDATORY INSTRUCTIONS

1. Students should report to the labs concerned as per the timetable.
2. Record should be updated from time to time and the previous experiment must be signed by the faculty in charge concerned before attending the lab.
3. Students who turn up late to the labs will in no case be permitted to perform the experiment scheduled for the day.
4. After completion of the experiment, certification of the staff in-charge concerned in the observation book is necessary.
5. Students should bring a notebook of about 100 pages and should enter the readings/observations/results into the notebook while performing the experiment.
6. The record of observations along with the detailed experimental procedure of the experiment performed in the immediate previous session should be submitted and certified by the staff member in-charge.
7. Not more than FIVE students in a group are permitted to perform the experiment on a set up.
8. The group-wise division made in the beginning should be adhered to, and no mix up of student among different groups will be permitted later.
9. The components required pertaining to the experiment should be collected from Lab- in-charge after duly filling in the requisition form.
10. When the experiment is completed, students should disconnect the setup made by them, and should return all the components/instruments taken for the purpose.
11. Any damage of the equipment or burnout of components will be viewed seriously either by putting penalty or by dismissing the total group of students from the lab for the semester/year.
12. Students should be present in the labs for the total scheduled duration.
13. Students are expected to prepare thoroughly to perform the experiment before coming to Laboratory.
14. Procedure sheets/data sheets provided to the students groups should be maintained neatly and are to be returned after the experiment.

Experiment No - 01

TENSION TEST

AIM:

To determine ultimate tensile stress of a metal.

OBJECTIVE:

To conduct a tensile test on a mild steel specimen and determine the following:

1. Limit of proportionality
2. Elastic limit
3. Yield strength
4. Ultimate strength
5. Young's modulus of elasticity
6. Percentage elongation
7. Percentage reduction in area.

APPARATUS:

1. Universal Testing Machine (UTM)
2. Mild steel specimens
3. Graph paper
4. Scale
5. Vernier Caliper

DIAGRAM

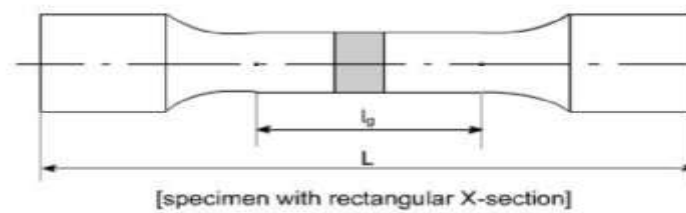
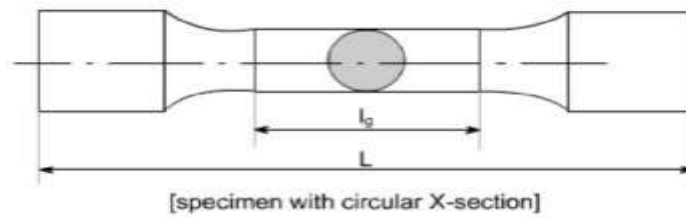
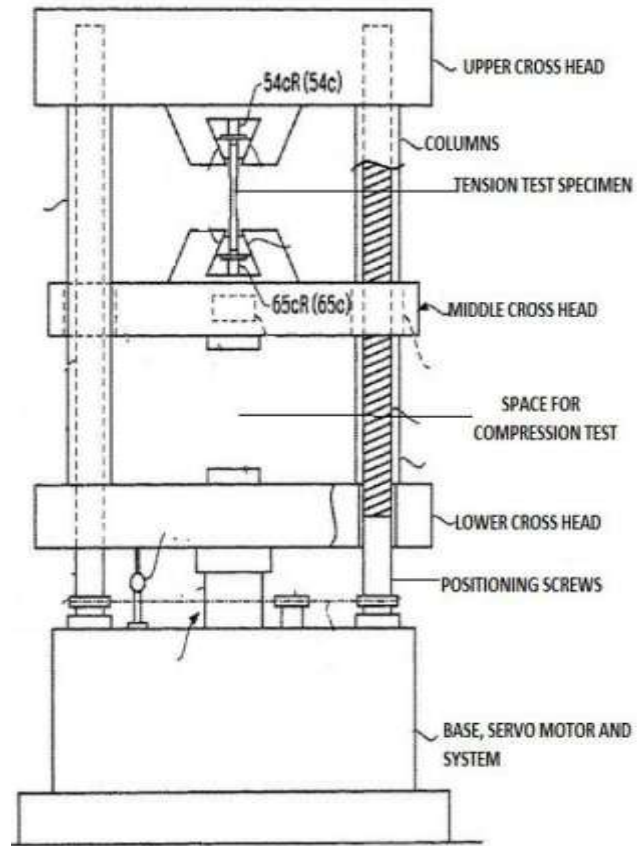

M/C SPECIFICATIONS:

Capacity: 400 KN.

Model: UTK-40.

SR. No:

2013/1073.

Mfd. By: Krystal Equipments, Ichalkaranji, M.H, India.

THEORY: -

The tensile test is most applied one, of all mechanical tests. In this test ends of test piece are fixed into grips connected to a straining device and to a load measuring device. If the applied load is small enough, the deformation of any solid body is entirely elastic. An elastically deformed solid will return to its original form as soon as load is removed. However, if the load is too large, the material can be deformed permanently. The initial part of the tension curve which is recoverable immediately after unloading is termed. As elastic and the rest of the curve which represents the manner in which solid undergoes plastic deformation is termed plastic. The stress below which the deformations essentially entirely elastic is known as the yield strength of material. In some material the onset of plastic deformation is denoted by a sudden drop in load indicating both an upper and a lower yield point. However, some materials do not exhibit a sharp yield point. During plastic deformation, at larger extensions strain hardening cannot compensate for the decrease in section and thus the load passes through a maximum and then begins to decrease. This stage the “ultimate strength” which is defined as the ratio of the load on the specimen to original cross-sectional area, reaches a maximum value. Further loading will eventually cause neck formation and rupture.

PROCEDURE: -

1. Measure the original length and diameter of the specimen. The length may either be length of gauge section which is marked on the specimen with a preset punch or the total length of the specimen
2. Insert the specimen into grips of the test machine and attach strain-measuring device to it.
3. Begin the load application and record load versus elongation data.
4. Take readings more frequently as yield point is approached.
5. Measure elongation values with the help of dividers and a ruler.
6. Continue the test till Fracture occurs.
7. By joining the two broken halves of the specimen together, measure the final length and diameter of specimen.

DESCRIPTION OF UTM AND EXTENSOMETER:

LOADING UNIT: -

It consists of main hydraulic cylinder with robust base inside. The piston which moves up and down. The chain driven by electric motor which is fitted on left hand side. The screw column maintained in the base can be rotated using above arrangement of chain. Each column passes through the main nut which is fitted in the lower cross head. The lower table connected to main piston through a ball & the ball seat is joined to ensure axial loading. There is a connection between lower table and upper head assembly that moves up and down with main piston. The measurement of this assembly is carried out by number of bearings which slides over the columns. The test specimen each fixed in the job is known as „Jack Job“. To fix up the specimen tightly, the movement of jack job is achieved helically by handle.

CONTROL PANEL: -

It consists of oil tank having a hydraulic oil level sight glass for checking the oil level. The pump is displacement type piston pump having free plungers those ensure for continuation of high pressure. The pump is fixed to the tank from bottom. The suction & delivery valve are fitted to the pump near tank. Electric motor driven the pump is mounted on four studs

which is fitted on the right side of the tank. There is an arrangement for loosening or tightening of the valve. The four valves on control panel control the oil stroke in the hydraulic system. The loading system works as described below. The return valve is closed, oil delivered by the pump through the flow control valves to the cylinder & the piston goes up. Pressure starts developing & either the specimen breaks or the load having maximum value is controlled with the base dynamometers consisting in a cylinder in which the piston reciprocates.

METHOD OF TESTING:

Initial Adjustment: - before testing adjust the pendulum with respect to capacity of the test i.e. 8 Tones; 10 Tones; 20 Tones; 40 Tones etc. For ex: - A specimen of 6 tones capacity gives more accurate result of 10 Tones capacity range instead of 20 Tones capacity range. These ranges of capacity are adjusted on the dial with the help of range selector knob. The control weights of the pendulum are adjusted correctly. The ink should be inserted in pen holder of recording paper around the drum & the testing process is started depending upon the types of tests.

EXTENSOMETER: -

This instrument is an attachment to Universal / Tensile Testing Machines. This measures the elongation of a test piece on load for the set gauge length. The least count of measurement being 0.01 mm, and maximum elongation measurement up to 3 mm. This elongation measurement helps in finding out the proof stress at the required percentage elongation.

WORKING OF THE INSTRUMENT: -The required gauge length (between 30 to 120) is set by adjusting the upper knife edges (3). A scale (2) is provided for this purpose. Hold the specimen in the upper and lower jaws of Tensile / Universal Testing Machine. Position the extensometer on the specimen. Position upper clamp (4) to press upper knife edges on the specimen. The extensometer will be now fixed to the specimen by spring pressure. Set zero on both the dial gauges by zero adjust screws (7). Start loading the specimen and take the reading of load on the machine at required elongation or the elongation at required load. Force setter accuracies mean of both the dial gauge (8) readings should be taken as

elongation. It is very important to note & follow the practice of removing the extensometer from the specimen before the specimen breaks otherwise the instrument will be totally damaged. As a safety, while testing the instrument may be kept hanging from a fixed support by a slightly loose thread.

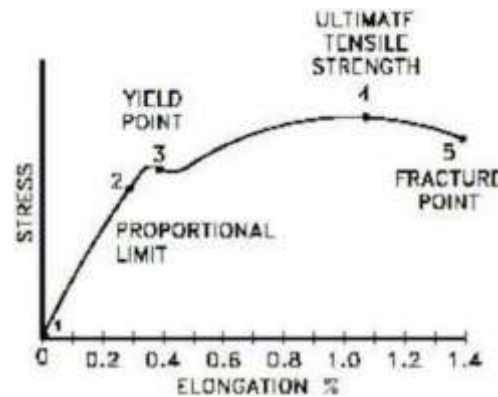

Stress-strain graph of Mild Steel

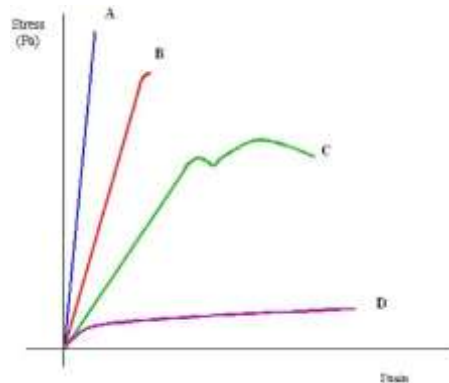

Stress-strain graphs of different materials.

- Curve **A** shows a **brittle** material. This material is also strong because there is little strain for a high stress. The fracture of a brittle material is sudden and catastrophic, with little or no plastic deformation. Brittle materials crack under tension and the stress increases around the cracks. Cracks propagate less under compression.
- Curve **B** is a **strong** material which is not ductile. Steel wires stretch very little, and break suddenly. There can be a lot of elastic strain energy in a steel wire under tension and it

will “whiplash” if it breaks. The ends are razor sharp and such a failure is very dangerous indeed.

- Curve **C** is a **ductile** material
- Curve **D** is a **plastic** material. Notice a very large strain for a small stress. The material will not go back to its original length.

OBESERVATIONS:

A) Original dimensions Gauge Length = -----

Diameter = -----

Area = -----

B) Final Dimensions:

Gauge Length = -----

Diameter = -----

Area = -----

TABULATION: - (Cross check ‘E’ with reference table 1.0)

SL No	Extension (mm)		Load (N)		Average load	Young’s Modulus
	Left	Right	Left	Right		
1						
2						
3						
4						
5						
6						

$$\text{unit of proportion} = \frac{\text{load at limit of proportioning}}{\text{original area of cross section}}$$

$$\text{Elastic limit} = \frac{\text{load at elastic limit}}{\text{original cross section area}} \text{N/mm}^2$$

$$\text{Yield strength} = \frac{\text{Maximum Tensile Strength}}{\text{original area of cross section}}$$

$$\text{Young's Modulus} = \frac{\text{stress below proportionality}}{\text{corresponding stress}}$$

$$\% \text{ of elongation} = \frac{\text{Final length (at fracture)} - \text{original length}}{\text{original length}}$$

$$\% \text{ of reduction in area} = \frac{\text{original area} - \text{original area at fracture}}{\text{original area}}$$

Experiment No - 02

BENDING TEST ON CANTILEVER BEAM

AIM:

This experiment is to demonstrate the effect of distance at which the load acting from the fixed end on deflection of the beam

The effects of young's modulus of the material of the beam using different materials bars.

The effect of the type of cross section on the deflection because of the effect of moment of inertia of the beam.

Determine the bending stress

THEORY:

A Cantilever is a Beam one end of which is clamped and another end is free.

A beam with a length L and is fixed at one end and the other end is free. Let the moment of inertia of the Beam is „ I “ about it's neutral axis and the Young's Modulus be „ E “.

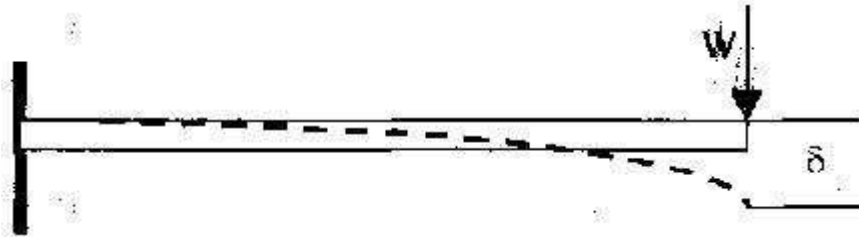

Moment of inertia about the neutral axis $I = \frac{bh^3}{12}$

Deflection at the end where point load is acting = =

□

The deflection at the end (Max deflection) □ is related to the load „ W “, length „ L “ moment of Inertia „ I “ and Young's Modulus „ E “ through the equation

$$\delta = \frac{WL^3}{3EI}$$

We can observe that

- i. If load is doubled deflection will also be doubled
- ii. If span is doubled deflection increases by 8 times.
- iii. If Young's Modulus of material is more, then deflection will be less.
- iv. If Moment of Inertia is increased the deflection will be reduced.

PROCEDURE

- i. Clamp the Beam horizontally on the clamping support at one end.
- ii. Measure the length of cantilever L (distance from clamp end to loading point)
- iii. Fix the dial gauge under the beam at the loading point to read down-ward moment and set to zero.
- iv. Hang the loading Pan at the free end of the cantilever.
- v. Load the cantilever with different loads (W) and note the dial gauge readings
- vi. Change the length of cantilever for two more different lengths repeat the experiment.
- vii. Change the position of cantilever and repeat the experiment for the other value of I for rectangular cross-section.

PRECAUTIONS:

- i. Beam should be positioned Horizontally
- ii. The length of the cantilever should be measured properly
- iii. The dial gauge spindle knob should always touch the beam at the bottom of loading point.
- iv. Loading hanger should be placed at known distance of cantilever length.
- v. All the errors should be eliminated while taking readings.
- vi. Elastic limit of the Beam should not exceed.

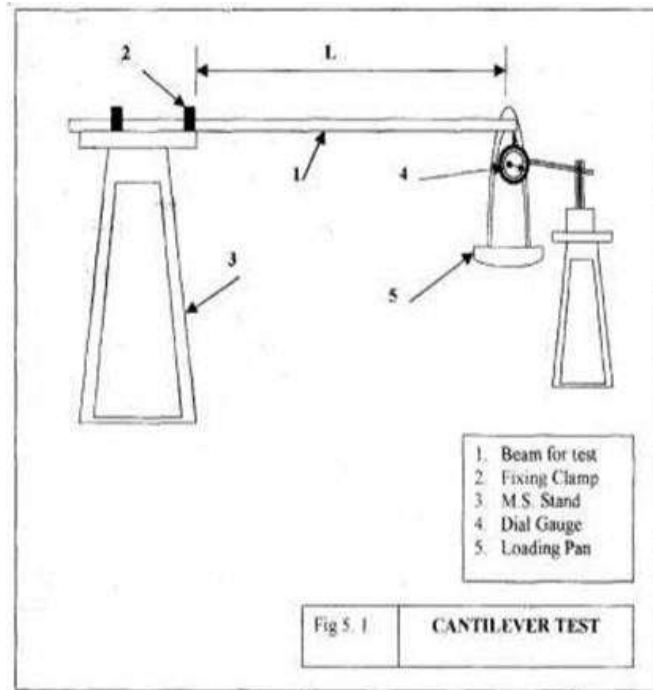

Experiment No: - 03

DEFLECTION TEST ON SIMPLY SUPPORTED BEAM

AIM:

To determine young's modulus of elasticity of material of beam simply supported at ends.

OBJECTIVE:

To find the values of bending stresses and young's modulus of elasticity of the material of a beam simply supported at the ends and carrying a concentrated load at the center.

APPARATUS: -

1. Deflection of beam apparatus
2. Pan
3. Weights
4. Beam of different cross-sections and material (say wooden and Steel beams)

DIAGRAM: -

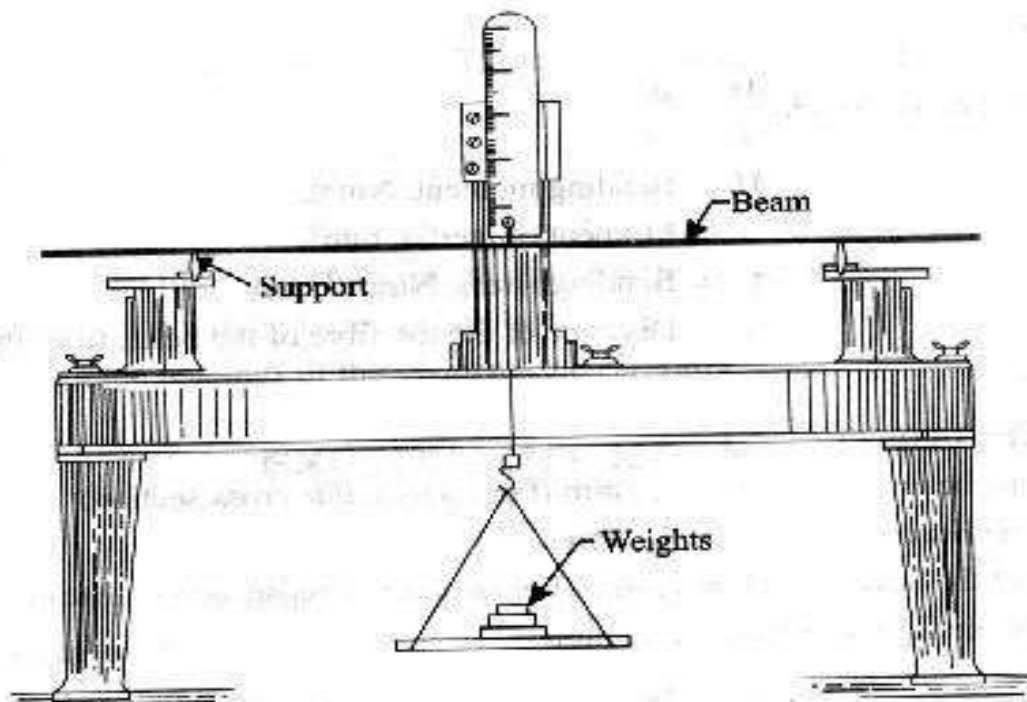

● **Fig. 13. Deflection of beam apparatus.**

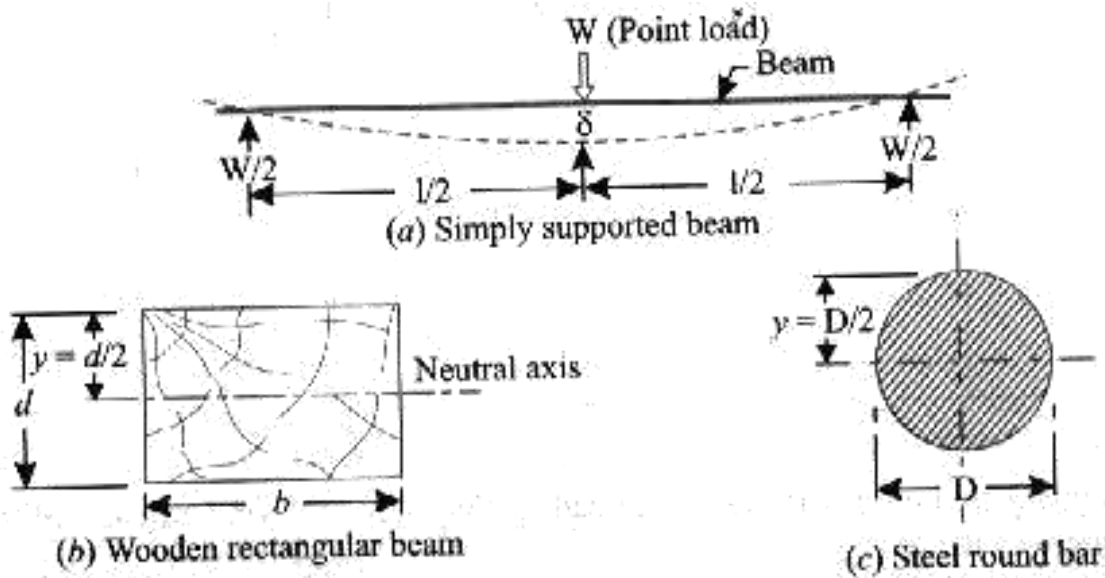

Fig. 14

THEORY: -

If a beam is simply supported at the ends and carries a concentrated load at its center, the beam bends concave upwards. The distance between the original position of the beams and its position after bending at different points along the length of the beam, being maximum at the center in this case. This difference is known as „deflection“ In this particular type of loading the maximum amount of deflection (δ) is given by the

$$\delta = \frac{Wl^3}{48EI} \dots\dots\dots (i)$$

$$E = \frac{Wl^3}{48\delta I} \dots\dots\dots (ii)$$

W = Load acting at center, N

L = Length of the beam between the supports mm

E = Young's modulus of material of the beam, N/mm²

I = Second moment of area of the cross- section (i.e, moment of Inertia) of the beam, about the neutral axis, mm.⁴

BENDING STRESS

As per bending equation $\frac{M}{I} = \frac{\sigma_b}{Y}$

Where

M = Bending Moment N-mm

I = Moment of inertia mm⁴

σ_b = Bending stress, N/mm², and

Y = Distance of the top fiber of beam from the neutral axis

PROCEDURE:

- 1 Adjust cast- iron block along the bed so that they are symmetrical with respect to the length of the bed.
- 2 Place the beam on the knife edges on the block so as to project equally beyond each knife edge. See that the load is applied at the center of the beam
- 3 Note the initial reading of Vernier scale.
- 4 Add a weight of 20N (say) and again note the reading of the Vernier scale.
- 5 Go on taking readings adding 20N (say) each time till you have minimum six readings.
- 6 Find the deflection (δ) in each case by subtracting the initial reading of Vernier scale.
- 7 Draw a graph between load (W) and deflection (δ). On the graph choose any two convenient points and between these points find the corresponding values of W and δ . Putting these Values in the relation

$$\delta = \frac{Wl^3}{48EI}$$

Calculate the value of E

8. Calculate the bending stresses for different loads using relation

$$\delta_b = \frac{MY}{I}$$

As given in the observation table

OBSERVATION TABLE: -

Sl No	Load W (N)	Bending Moment $M = \frac{Wl}{4} (N - mm^3)$	Bending Stress $\sigma_b = \frac{MY}{I}$	Deflection δ	Young's Modulus of elasticity $E = \frac{Wl^3}{48\delta I}$

RESULT:

1. The young's modulus for steel beam is found to be -----N/mm².
2. The young's modulus for wooden beam is found to be-----N/mm²

PRECAUTION

1. Make sure that beam and load are placed a proper position.
2. The cross- section of the beam should be large.
3. Note down the readings of the Vernier scale carefully

Experiment No - 04

TORSION TEST

OBJECTIVE:

To conduct torsion test on mild steel or cast-iron specimen to determine modulus of rigidity.

APPARATUS:

1. A torsion test machine along with angle of twist measuring attachment.
2. Standard specimen of mild steel or cast iron.
3. Steel rule.
4. Vernier caliper or a micrometer.

Torsion testing machine:



M/C SPECIFICATIONS:

Capacity: Torque Range: 0-10 Kg-m.

Model: TTM-10.

SR.No: 2001/1012.

Mfd. By: Macro Testing Machines, Ichalkaranji, M.H, India.

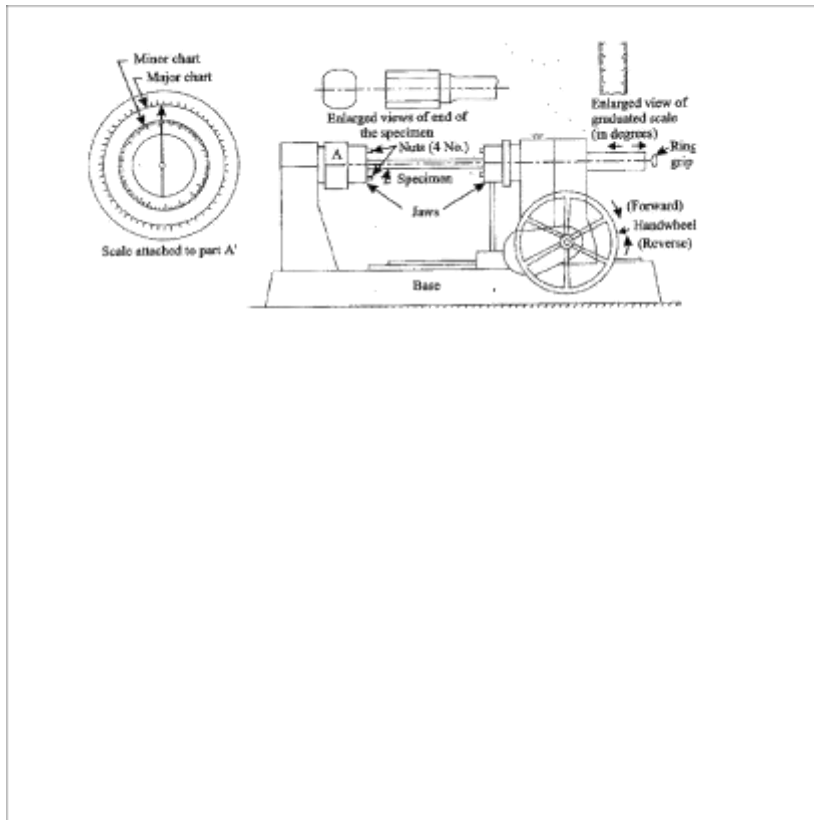

THEORY:

For transmitting power through a rotating shaft, it is necessary to apply a turning force. The force is applied tangentially and in the plane of transverse cross section. The torque or twisting moment may be calculated by multiplying two opposite turning moments. It is said to be in pure torsion and it will exhibit the tendency of shearing off at every cross section which is perpendicular to the longitudinal axis.

Torsion equation:

Torsion equation is given by below

$$T/J = \tau/R = G\theta/L$$

$$G = T L/J \theta \text{ N/mm}^2$$

$$T = \text{maximum twisting torque (N mm)}$$

$$J = \text{polar moment of inertia (mm}^4\text{)} = \pi d^4/32 \quad \tau = \text{shear stress (N/mm}^2\text{)}$$

$$G = \text{modulus of rigidity (N/mm}^2\text{)} \quad \theta = \text{angle of twist in radians}$$

$$L = \text{length of shaft under torsion (mm)}$$

Assumptions made for getting torsion equation

1. The material of the shaft is uniform throughout.
2. The shaft, circular in section remain circular after loading.
3. Plane sections of shaft normal to its axis before loading remain plane after the torque have been applied.
4. The twist along the length of the shaft is uniform throughout.
5. The distance between any two normal-sections remains the same after the application of torque.
6. Maximum shear stress induced in the shaft due to application of torque does not exceed its elastic limit.

PROCEDURE:-

1. Select the driving dogs to suit the size of the specimen and clamp it in the machine by adjusting the length of the specimen by means of a sliding spindle.
2. Measure the diameter at about three places and take the average value.
3. Choose the appropriate range by capacity change lever
4. Set the maximum load pointer to zero.
5. Set the protractor to zero for convenience and clamp it by means of knurled screw.
6. Carry out straining by rotating the hand wheel in either direction.
7. Load the machine in suitable increments.
8. Then load out to failure as to cause equal increments of strain reading.
9. Plot a torque- twist ($T- \theta$) graph.
10. Read off co-ordinates of a convenient point from the straight-line portion of the torquetwist ($T-\theta$) graph and calculate the value of G by using relation.

OBSERVATIONS:-

Gauge length of the specimen, $L = \dots\dots\dots$

Diameter of the specimen, $d = \dots\dots\dots$

Polar moment of inertia, $J = \pi d^4/32 = \dots\dots\dots$

TABULATION: (Cross check 'G' with reference table 1.0)

Sl. No.	Torque, Kg-cm	Torque, N - mm	Angle of twist		Modulus Rigidity, G N/mm ²	Average G, N/mm ²
			Degrees	Radians		

RESULT: -

Thus, the torsion test on given mild steel specimen is done and the modulus of rigidity is -----
-N/mm².

GRAPH:

Torque Vs Angle of Twist

PRECAUTIONS: -

- 1) Measure the dimensions of the specimen carefully
- 2) Measure the Angle of twist accurately for the corresponding value of Torque.
- 3) The specimen should be properly to get between the jaws.
- 4) After breaking specimen stop to m/c.

Viva Questions

1. Define torque.
2. Give the expression for torque.
3. Define modulus of rigidity.
4. Give the values of G for different materia

Experiment No – 05

HARDNESS TEST

OBJECTIVE: -

To conduct hardness test on mild steel, carbon steel, brass and aluminum specimens.

APPARATUS: -

Hardness tester, soft and hard mild steel specimens, brass, aluminum etc.

DIAGRAM: -



Nomenclature	Specifications
Loads	60, 100, 150, 187.5, 250 (kgf)
Initial Load	10 (kgf)
Max. Test Height	230 (mm)
Depth of Throat	133 (mm)
Max. Depth of elevating screw below base	240 (mm)
Size of Base (approx)	171 x 423 (mm)
Machine Height	635 (mm)
Net. weight (Approx)	75 Kg

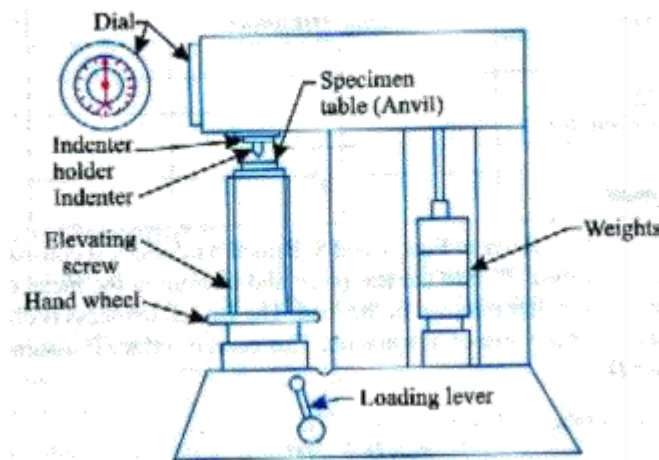

THEORY: -

The hardness of a material is resistance to penetration under a localized pressure or resistance to abrasion. Hardness tests provide an accurate, rapid and economical way of determining the resistance of materials to deformation. There are three general types of hardness measurements depending upon the manner in which the test is conducted:

- A. Scratch hardness measurement,
- B. Rebound hardness measurement
- C. Indention hardness measurement.

In scratch hardness method the material are rated on their ability to scratch one another and it is usually used by mineralogists only. In rebound hardness measurement, a standard body is usually dropped on to the material surface and the hardness is measured in terms of the height of its rebound. The general means of judging the hardness is measuring the resistance of a material to indentation. The indenters usually a ball cone or pyramid of a material much harder than that being used. Hardened steel, sintered tungsten carbide or diamond indenters are generally used in indentation tests; a load is applied by pressing the indenter at right angles to the surface being tested. The hardness of the material depends on the resistance which it exerts during a small amount of yielding or plastic. The resistance depends on friction, elasticity, viscosity and the intensity and distribution of plastic strain produced by a given tool during indentation.

BRINELL'S HARDNESS TEST

AIM:

To find the brinell's hardness number of the given metals using brinell's hardness testing machine.

APPARATUS:

Brinell's hardness tester, Optical microscope.

THEORY:

Hardness of a material is generally defined as Resistance to permanent indentation under static or dynamic loads. However, it also refers to stiffness or to resistance to scratching, abrasion or cutting. Indentation hardness may be measured by various hardness tests, such as Rockwell, Vickers, Brinell's hardness etc. In Brinell's hardness test, a hard steel ball, under specified conditions of load and time, is forced into the surface of the material under test and the diameter of the impression is measured. Hardness number is defined as the load in kilograms per square millimeters of the surface area of indentation. This number depends on the magnitude of the load applied, material and geometry of the indenter.

For the Brinell's hardness number, the diameter of the indenter and load shall be taken from the following table:

Ball dia (D)	Load kilograms		
	Ferrous metals	Nonferrous metals	
	Steel & iron $30 D^2$	Brass $10 D^2$	Aluminum $5 D^2$
10 mm	3000	1000	500
5 mm	750	250	—

Brinell's hardness number (HB) is given by

$$HB = \frac{\text{Load on ball in kg}}{\text{Surface area of indentation in sq.mm}}$$

$$\frac{2P}{\pi D(d - \sqrt{D^2 - d^2})}$$

Where: P=load in kg
D=diameter of indenter in mm
d=average diameter of impression in mm

PROCEDURE:

- Select the proper diameter of the indenter and load.
- Start the machine by pushing the green button of starter and allow oil to circulate for few minutes.
- Keep the hand lever in position A.
- Place the specimen securely on the testing table. Turn the hand wheel in clockwise direction, so that the specimen will push the indenter and will show a reading on dial gauge. The movement will continue until the long pointer will stop at „0“ and small pointer at red dot when the initial load of 250kg is applied. If little error exists the same can be adjusted by rotating the outer ring dial gauge.
- Turn the handle from position „A“ to „B“ so that the total system is brought into action.
- When the long pointer of dial gauge reaches a steady position, the load may be released by taking back the lever to position „A“.
- Turn back the hand wheel and remove the specimen.
- The diameter of the impression can be found by using optical microscope.
- Read the hardness number from the tables.

OBSERVATIONS:

Table: 1.1

SI No	Material	Load	Diameter of impression(mm)	BHN(kg/mm ²)
1				
2				
3				
4				

Model Table

SI No.	Material	Load	Diameter of impression(mm)	BHN(kg/mm ²)
1	EN-8	3000	5	144.6
2	EN-24	3000	4.4	142.6
3	Stainless steel(SS)	3000	4.8	155.2
4	Aluminum(Al)	500	3	69.15

Important Viva Questions:

1. What is the relation between Brinell's hardness number and Rockwell's hardness number

PRECAUTIONS:

1. Operate the hand lever from A to B several times to raise and lower the weights in order to eliminate air from the hydraulic system.
2. Operate it slowly for accurate results.

RESULT:

The Brinell's hardness number of EN-8 _____

The Brinell's hardness number of EN-24 _____

The Brinell's hardness number of Stain less Steel _____

The Brinell's hardness number of Alluminium _____

BRINNELL'S HARDNESS TESTING MACHINE



ROCKWELL'S HARDNESS TEST

AIM:

To determine Rockwell hardness number for a given specimen.

APPARATUS:

Rock well hardness testing machine.

THEORY:

PROCEDURE:

1. Adjust the weights on the plunger of dash pot according to Rockwell scale as shown in chart.
2. Keep the lever in position A.
3. Place the specimen on testing table.
4. Turn the hand wheel clockwise, on that specimen will push the indenter and the small pointer moves to the red spot (Do not turn the wheel in a way to cross the red spot). The long pointer automatically stops at zero on black scale. If there is any resistance, unload and check the weights, indenter and the gap between inner faces of hanger and turn the lever from position A to B slowly so that the total load is brought in to action without any jerks.

The long pointer of dial gauge reaches a steady position when indentation is complete. Take back the lever to position A slowly.

5. Read the figure against the long pointer. That is direct reading of the hardness of specimen.
6. Turn back the hand wheel and remove the specimen.
7. Repeat the procedure 3 to 4 times.

Choice of Loads and Indentor for various hardness tests:

Total load	588.4N	980.7N	1471N	1839N	2452N
indentor	Diamond 120^0	Ball 1.558mm dia.	Diamond 120^0	Ball 2.5mm dia	Ball 5mm dia
scale	A	B	C	Brinell $30 D^2$	Brinne $110D^2$
Dial to be read	Black	Red	black
Typical applications	Thin steel & shallow case Hardened steel	Soft steel, malleable, copper & Aluminum alloys.	Steel, hard, cast steel, deep case-hardened steel, other metals, harder than HRB-100	Steel and cast iron	Copper and aluminum alloys

OBSERVATIONS:

Table 2.1

S.NO	MATERIAL	ROCKWELL SCALE OF WEIGHTS PLACED			ROCK WELL
		SCALE	WEIGHT	INDENTOR	
1					
2					
3					
4					

Model Observations:

Sl.No	MATERIAL	ROCKWELL SCALE OF WEIGHTS PLACED			ROCK WELL
		SCALE	WEIGHT	INDENTOR	
1	EN-36	B	100	1/16"	B98
2	EN-24	B	100	1/16"	B95
3	SS	B	100	1/16"	B87
4	BRASS	B	100	1/16"	B61
5	ALLUMINIUM	B	100	1/16"	B40

PRECAUTIONS:

1. Select the proper indenter and load to suit the material under the Test.
2. Surface to be tested must be sufficiently smooth and free from any defects.
3. The surface under the test must be at right angle to the axis of the indenter.
4. Diamond indenter has highly polished surface and is Susceptible to damage if not handled properly.

RESULT:

The rock well hardness number for Mild Steel is _____

The rock well hardness number for Copper is _____

The rock well hardness number for Aluminum _____

The rock well hardness number for Brass is _____



ROCKWELL'S HARDNESS TESTING MACHIN

Experiment No – 06

SPRING TEST

OBJECTIVE:

To determine the stiffness and modulus of rigidity of the spring wire.

APPARATUS: -

1. Spring testing machine.
2. A spring
3. Vernier caliper, Scale.
4. Micrometer.

DIAGRAM:-

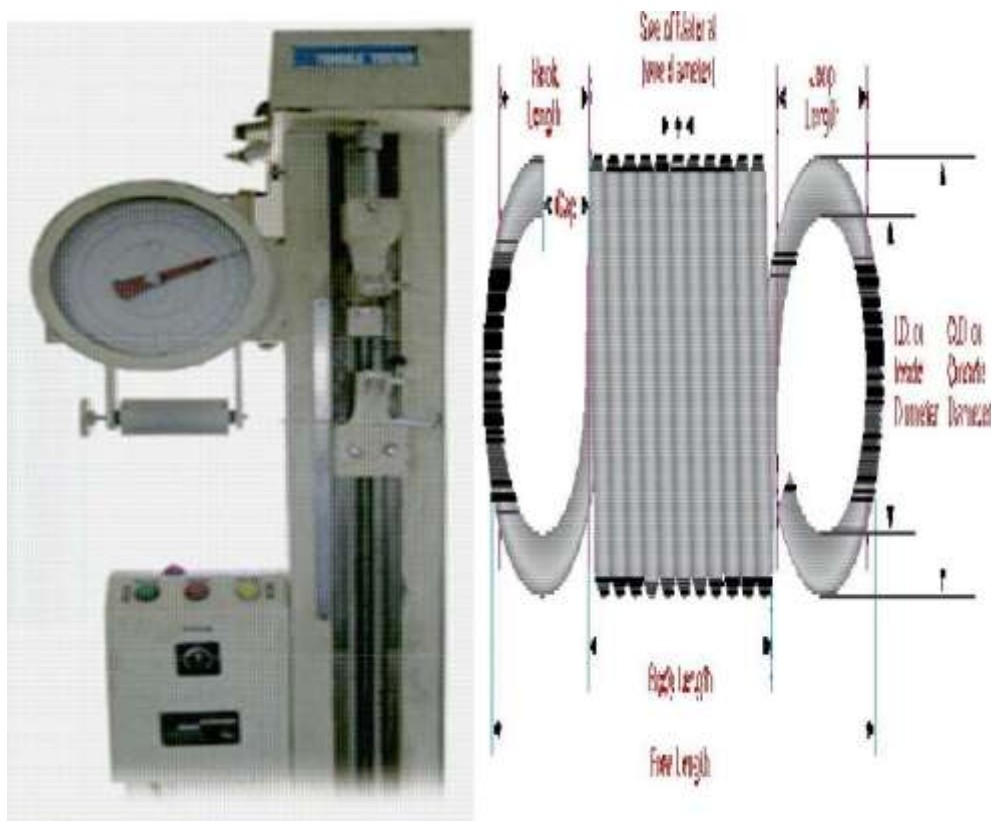

M/C SPECIFICATIONS:

Capacity: 0-250 Kgf.

Model: MX-250

SR.No: 2001/1001.

Mfd. By: Macro Testing Machines, Ichalkaranji, M.H, India.

THEORY: -

Springs are elastic member which distort under load and regain their original shape when load is removed. They are used in railway carriages, motor cars, scooters, motorcycles, rickshaws, governors etc. According to their uses the springs perform the following Functions:

- 1) To absorb shock or impact loading as in carriage springs.
- 2) To store energy as in clock springs.
- 3) To apply forces to and to control motions as in brakes and clutches.
- 4) To measure forces as in spring balances.

To change the variations characteristic of a member as in flexible mounting of motors. The spring is usually made of either high carbon steel (0.7 to 1.0%) or medium carbon alloy steels. Phosphor bronze, brass, 18/8 stainless steel and Monel and other metal alloys are used for corrosion resistance spring. Several types of spring are available for different application. Springs may be classified as helical springs, leaf springs and flat spring depending upon their shape. They are fabricated of high shear strength materials such as high carbon alloy steels. Spring form elements of not only mechanical system but also structural system. In several cases it is essential to idealize complex structural systems by suitable spring.

PROCEDURE:

1. Measure the outer diameter (D) and diameter of the spring coil (d) for the given compression spring.
2. Count the number of turns i.e. coils (n) in the given compression specimen.
3. Place the compression spring at the center of the bottom beam of the spring testing machine.
4. Insert the spring in the spring testing machine and load the spring by a suitable weight and note the corresponding axial deflection in tension or compression.
5. Note down the initial reading from the scale in the machine.
6. Increase the load and take the corresponding axial deflection readings.
7. Find the actual deflection of the spring for each load by deducting the initial scale reading from the corresponding scale reading.
8. Calculate the modulus of rigidity for each load applied.
9. Plot a curve between load and deflection. The shape of the curve gives the stiffness of the spring.

FORMULA:

$$\text{Modulus of rigidity, } G = \frac{64WR^3 n}{\delta d^4}$$

Where

1. W = Load in N
2. R = Mean radius of the spring in mm $(D - (d/2))/2$
3. d = Diameter of the spring coil in mm
4. δ = Deflection of the spring in mm
5. D = Outer diameter of the spring in mm.

OBSERVATIONS:

1. Material of the spring specimen =
2. Least count of micrometer = mm
3. Diameter of the spring wire, d = mm (Mean of three readings)
4. Least count of Vernier Caliper = mm
5. Diameter of the spring coil, D = mm (Mean of three readings)
6. Number of turns, n =
7. Initial scale reading = mm

Sl No.	Applied Load		Scale	Actual Deflection, mm	Modulus of Rigidity, GPa	Stiffness, N/mm
	Kg	N	Reading, mm			
1						
2						
3						
4						
5						

TABULATION: (Refer Tables)

RESULT:

The modulus of rigidity of the given spring = -----GPa

The stiffness of the given spring =-----N/mm²

GRAPH:

Load Vs Deflection

PRECAUTIONS: -

- 1) Dimensions should be measure accurately with the help of Vernier Calipers.
- 2) Deflection from the scale should be noted carefully and accurately.

Properties of common spring materials (Adopted from ace wire spring and form company)

	Material	Nominal Analysis	Tensile	Properties	Torsional	Properties	Max. Operating Temp. °F	Max. Operating Temp. °C	Rockwell hardness	Method of Manufacture Chief Uses Special Properties
			Minimum Tensile Strength	Modulus of Elasticity E	Design Stress % Min. Tensile	Modulus in Torsion G				
			psi x 10 ³ (MPa)	psi x 10 ⁶ (MPa x 10 ³)		psi x 10 ⁶ (MPa x 10 ³)				
High Carbon Spring Wires	Music Wire ASTM A 228	C 0.70-1.00% Mn 0.20-0.60%	230-399 (1586-2751)	30 (207)	45	11.3 (79.3)	250	121	C41-60	Cold drawn high and uniform tensile. High quality springs and wire forms. Suitable for cyclic applications.
	Hard Drawn ASTM A 227	C 0.45-0.85% Mn 0.60-1.30%	CL1 147-283 (1014-1951) CL2 171-324 (1179-2234)	30 (207)	40	11.3 (79.3)	250	121	C31-52	Cold drawn. Average stress applications. Lower cost springs and wire forms.
	High Tensile Hard Drawn ASTM A 679	C 0.65-1.00% Mn 0.20-1.50%	238-350 (1641-2413)	30 (207)	45	11.3 (79.3)	250	121	c31-52	Cold Drawn. Higher Quality springs and wire forms.
	Oil Tempered ASTM A 229	C 0.55-0.85% Mn 0.60-1.20%	CL1 165-293 (1134-2020) CL2 191-324 (1317-2234)	30 (207)	45	11.3 (79.3)	250	121	C42-55	Cold drawn and heat treated before fabrication. General purpose spring wire.
	Carbon Valve ASTM A 230	C 0.60-0.75% Mn 0.60-0.90	215-240 (1482-1655)	30 (207)	45	11.3 (79.3)	250	121	C45-49	Cold drawn and heat treated before fabrication. Good surface and uniform tensile. Suitable for cyclic applications.

Alloy Steel Wire	Chrome Vanadium ASTM A 231	C 0.48-0.53% Cr 0.80-1.10% V 0.15 min %	190-300 (1310-2069)	30 (207)	45	11.3 (79.3)	425	218.5	C41-55	Cold drawn and heat treated before fabrication. Used for shock loads and moderately elevated temperature.
	Chrome Silicon ASTM A 401	C 0.51-0.39% Cr 0.60-0.80% Si 1.20-1.60%	235-300 (1620-2069)	30 (207)	45	11.3 (79.3)	475	246	C48-55	Cold drawn and heat treated before fabrication. Used for shock loads and moderately elevated temperature.

Stainless Steel Wire	AISI 302/304 ASTM A 313	Cr 17-19% Ni 8-10%	125-325 (862-2241)	28 (193)	35	30 (69.0)	550	288	C35-45	Cold drawn general purpose corrosion and heat resistant. Magnetic in spring temp.
	AISI 316 ASTM A 313	Cr 16-18% Ni 10-14% Mo 2-3%	110-245 (756-1689)	28 (193)	40	30 (69.0)	550	288	C35-45	Cold drawn. Heat resistant and better corrosion resistance than 302. Magnetic in spring temp.
	17-7 PH ASTM A 313 (B31)	Cr 16-18% Ni 10-14% Al 0.75-1.5%	Case C28 235-310 (1620-2100)	26.3 (201)	40	11 (79.3)	430	343	C36-37	Cold drawn and precipitation hardened after fabrication. High strength and general purpose corrosion resistance. Slightly magnetic in spring temp.

Non-Ferrous Alloy Wire	Phosphor Bronze Grade A ASTM B 159	Cu 94-96% Sn 4-6%	105-145 (724-1000)	15 (103)	40	6.25 (43.1)	200	93.3	B98-104	Cold drawn. Good corrosion resistance and electrical conductivity.
	Beryllium Copper ASTM B 197	Cu 98% Be 2%	150-230 (1034-1586)	18.5 (128)	45	7.0 (48.3)	400	204	C35-42	Cold drawn and may be mill hardened before fabrication. Good corrosion resistance and electrical conductivity. High physical.
	Monel 400 AMS 2233	Ni 80% Cu 31.5% C/Fe	145-180 (1000-1241)	26 (179)	40	9.5 (65.5)	450	232	C23-32	Cold drawn. Good corrosion resistance at moderately elevated temperature.
Monel K 500 QQ-N-286 ³	Ni 65.0% Cu 29.5% C/Fe/Al/Ti	160-200 (1103-1379)	26 (179)	40	9.5 (65.5)	550	28	C23-35	Excellent corrosion resistance at moderately elevated temperature.	

High Temperature Alloy Wire	A 286 Alloy	Ni 26% Cr 15% Fe 53%	160-200 (1103-1379)	29 (200)	35	10.4 (71.7)	950	510	C35-42	Cold drawn and precipitation hardened after fabrication. Good corrosion resistance at elevated temperature.
	Inconel 600 QQ-W-390 ³	Ni 76% Cr 13.8% Fe 7.2%	170-230 (1172-1586)	31 (214)	40	11.0 (75.3)	700	371	C35-45	Cold drawn. Good corrosion resistance at elevated temperature.
	Inconel 718	Ni 52.3% Cr 18.6% Fe 18.3%	210-230 (1448-1724)	29 (200)	40	11.2 (77.2)	1100	593	C45-50	Cold drawn and precipitation hardened after fabrication. Good corrosion resistance at elevated temperature.
Inconel x 750 AMS 5698, 5699	Ni 73% Cr 15% Fe 6.73%	No IT 155 Min. 1069 Sp. T 190-230 (1310-1586)	31 (214)	40	12 (82.7)	750-1100	399-593	C34-39 C42-48	Cold drawn and precipitation hardened after fabrication. Good corrosion resistance at elevated temperature.	

Experiment No. – 07

COMPRESSION TEST

OBJECTIVE: -

To perform compression test on UTM.

APPARATUS: -

1. UTM or A compression testing m/c,
2. Cylindrical or cube shaped specimen,
3. Vernier caliper,
4. Liner scale.

DIAGRAM: -



THEORY:-

Bricks are used in construction of either load bearing walls or in portion walls in case of frame structure. In bad bearing walls total weight from slab and upper floor comes directly through brick and then it is transversed to the foundation. In case the bricks are loaded with compressive nature of force on other hand in case of frame structure bricks are used only for construction of portion walls, layers comes directly on the lower layers or wall. In this case bricks are loaded with compressive nature of force. Hence for safely measures before using

the bricks in actual practice they have to be tested in laboratory for their compressive strength.

PROCEDURE: -

1. Select some brick with uniform shape and size.
2. Measure it's all dimensions. (LxBxH)
3. Now fill the frog of the brick with fine sand.
4. Place the brick on the lower platform of compression testing machine and lower the spindle till the upper motion of ram is offered by a specimen the oil pressure start increasing the pointer start returning to zero leaving the drug pointer that is maximum reading which can be noted down.

TABULATION: - (Refer Tables)

S. No.	L x B x H, Cm ³	Area, L x B, Cm ²	Load (P), N	Compressive Strength (P/A), KPa	Avg. Compressive Strength (P/A), KPa
1					
2					
3					
4					
5					

Material	Compression Strength		Tension Strength	
	(psi)	(kPa)	(psi)	(kPa)
Bricks, hard	12000	80000	400	2800
Bricks, light	1000	7000	40	280
Brickwork, common quality	1000	7000	50	350
Brickwork, best quality	2000	14000	300	2100
Granite	19000	130000	700	4800
Limestone	9000	60000	300	2100
Portland Cement, less than one month old	2000	14000	400	2800
Portland Cement, more than one year old	3000	21000	500	3500
Portland Concrete	1000	7000	200	1400
Portland Concrete, more than one year old	2000	14000	400	2800
Sandstone	9000	60000	300	2100
Slate	14000	95000	500	3500
Trap rock	20000	140000	800	5500

CALCULATION: -

Max. Load at failure

Compressive Strength = ----- **KPa**

Loaded Area of brick

RESULT: -

The average compressive strength of new brick sample is found to be..... **KPa**

PRECAUTIONS: -

- 1) Measure the dimensions of Brick accurately.
- 2) Specimen should be placed as for as possible in the of lower plate.
- 3) The range of the gauge fitted on the machine should not be more than double thebreaking load of specimen for reliable results.

Compressive and tensile strength of some common materials :

Experiment No: 08

IMPACT TEST (IZOD)

AIM: -

To determine the impact strength of steel by Izod impact test

APPARATUS: -

1. Impact testing machine
2. A steel specimen 75 mm X 10mm X 10mm

DIAGRAM:-



M/C SPECIFICATIONS:

Capacity: Energy range: i. Charpy: 0-300 J.

ii. Izod: 0-168 J.

Model: ITM-300

SR.No: 2001/1016.

Mfd. By: Macro Testing Machines, Ichalkaranji, M.H, India.

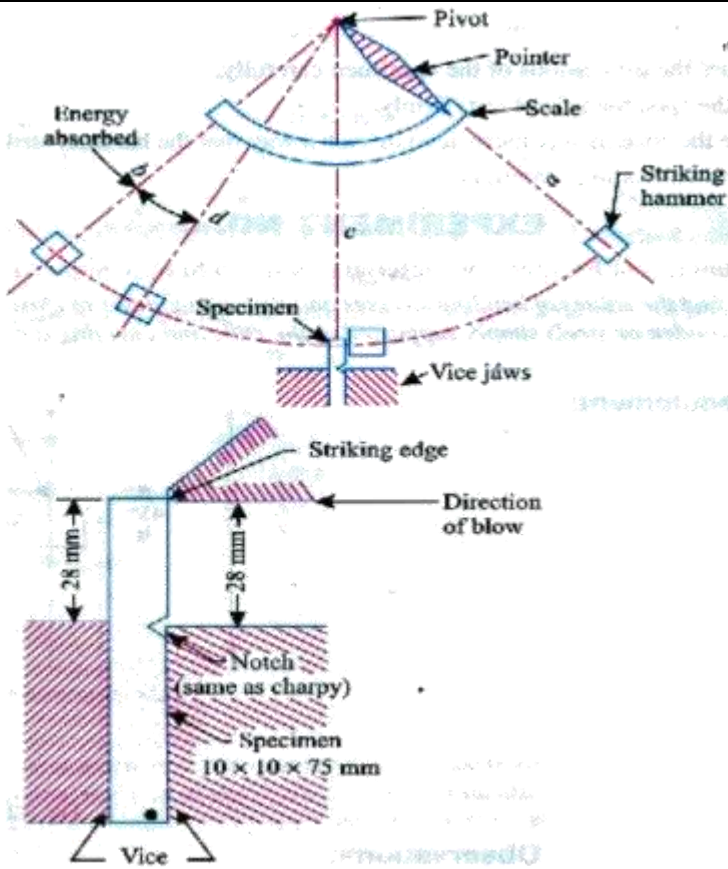

THEORY: -

An impact test signifies toughness of material that is ability of material to absorb energy during plastic deformation. Static tension tests of unnotched specimens do not always reveal the susceptibility of a metal to brittle fracture. This important factor is determined by impact test. Toughness takes into account both the strength and ductility of the material. Several engineering materials have to withstand impact or suddenly applied loads while in service. Impact strengths are generally lower as compared to strengths achieved under slowly applied loads. Of all types of impact tests, the notch bar tests are most extensively used. Therefore, the impact test measures the energy necessary to fracture a standard notch bar by applying an impulse load. The test measures the notch toughness of material under shock loading. Values obtained from these tests are not of much utility to design problems directly and are highly arbitrary. Still it is important to note that it provides a good way of comparing toughness of various materials or toughness of the same material under different condition. This test can also be used to assess the ductile brittle transition temperature of the material occurring due to lowering of temperature

PROCEDURE: -

(a) Izod test

1. With the striking hammer (pendulum) in safe test position, firmly hold the steel specimen in impact testing machine's vice in such a way that the notch face the hammer and is half inside and half above the top surface of the vice.
2. Bring the striking hammer to its top most striking position unless it is already there, and lock it at that position.
3. Bring indicator of the machine to zero, or follow the instructions of the operating manual supplied with the machine.
4. Release the hammer. It will fall due to gravity and break the specimen through its momentum; the total energy is not absorbed by the specimen. Then it continues to swing. At its topmost height after breaking the specimen, the indicator stops moving, while the pendulum falls back. Note the indicator at that topmost final position.
5. Again bring back the hammer to its idle position and back

OBSERVATIONS: -

Izod Test.

1. Impact value of - Mild Steel-----N-m
2. Impact value of - Brass -----N-m
3. Impact value of - Aluminum -----N-m

RESULT:-

- i. The energy absorbed for Mild Steel is found out to be (K) ----- Joules.
- ii. The energy absorbed for Brass is found out to be (K) ----- Joules.
- iii. The energy absorbed for Aluminium is found out to be (K) ----- Joules
- iv. Impact strength of the specimen, $(K/A) =$ ----- J/mm²

PRECAUTIONS:-

1. Measure the dimensions of the specimen carefully.
2. Hold the specimen (Izod test) firmly.
3. Note down readings carefully.

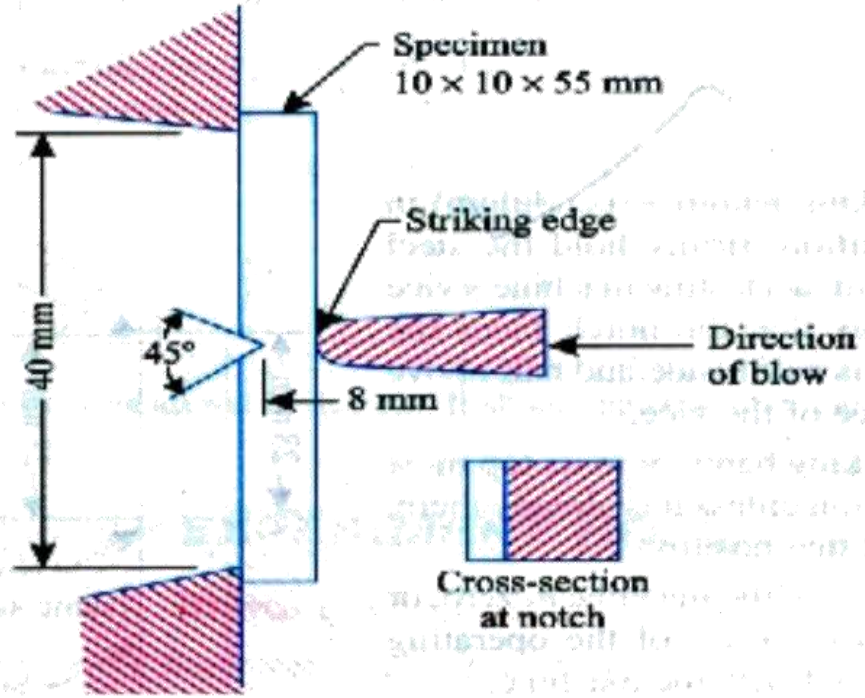
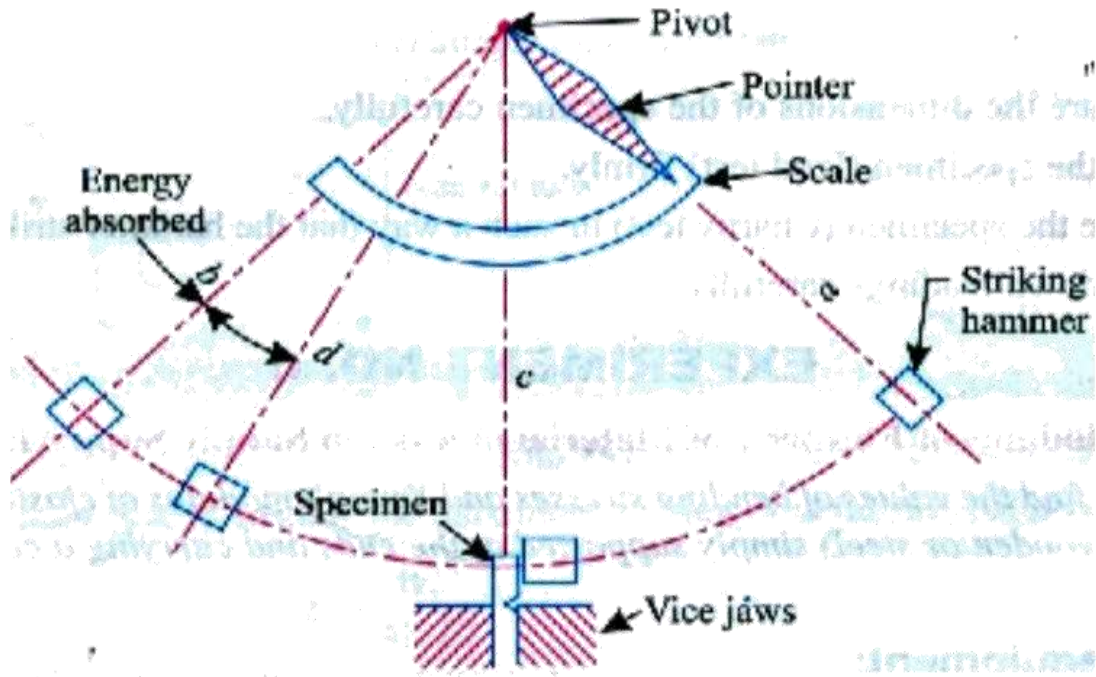

Experiment No – 08

b) IMPACT TEST (CHARPY)

AIM:

To determine impact strength of steel.

OBJECT: -

To determine the impact strength of steel by (Charpy test)

APPARATUS: -

1. Impact testing machine
2. A steel specimen 10 mm x 10 mm X 55mm

DIAGRAM:-

THEORY: -

An impact test signifies toughness of material that is ability of material to absorb energy during plastic deformation. Static tension tests of unmatched specimens do not always reveal

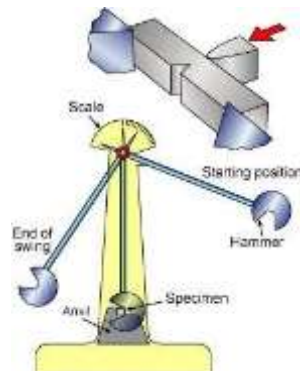

the susceptibility of a metal to brittle fracture. This important factor is determined by impact test. Toughness takes into account both the strength and ductility of the material. Several engineering materials have to withstand impact or suddenly applied loads while in service. Impact strengths are generally lower as compared to strengths achieved under slowly applied

loads. Of all types of impact tests, the notch bar tests are most extensively used. Therefore, the impact test measures the energy necessary to fracture a standard notch bar by applying an impulse load. The test measures the notch toughness of material under shock loading. Values obtained from these tests are not of much utility to design problems directly and are highly arbitrary. Still it is important to note that it provides a good way of comparing toughness of various materials or toughness of the same material under different condition. This test can also be used to assess the ductile brittle transition temperature of the material occurring due to lowering of temperature.

PROCEDURE: -

(b) Charpy Test

1. With the striking hammer (pendulum) in safe test position, firmly hold the steel specimen in impact testing machines vice in such a way that the notch faces the hammer and is half inside and half above the top surface of the vice.
2. Bring the striking hammer to its top most striking position unless it is already there, and lock it at that position.
3. Bring indicator of the machine to zero, or follow the instructions of the operating manual supplied with the machine.
4. Release the hammer. It will fall due to gravity and break the specimen through its momentum; the total energy is not absorbed by the specimen. Then it continues to swing. At its topmost height after breaking the specimen, the indicator stops moving, while the pendulum falls back. Note the indicator at that topmost final position.
5. The specimen is placed on supports or anvil so that the blow of hammer is opposite to the notch.

OBSERVATIONS: -

Charpy test

1. Impact value of - Mild Steel-----N-m
2. Impact value of - Brass -----N-m
3. Impact value of - Aluminum -----N-m

RESULT: -

- i. The energy absorbed for Mild Steel is found out to be (K)----- Joules.
- ii. The energy absorbed for Brass is found out to be (K)-----Joules.
- iii. The energy absorbed for Aluminum is found out to be (K)----- Joules
- iv. Impact strength of the specimen, $(K/A) = \text{-----} \text{J/mm}^2$

PRECAUTIONS: -

- 1 Measure the dimensions of the specimen carefully.
- 2 Locate the specimen (Charpy test) in such a way that the hammer, strikes it at the middle.
- 3 Note down readings carefully

Experiment No: 09

SHEAR STRENGTH OF GIVEN SPECIMEN

AIM: -

To find the shear strength of given specimen

APPARATUS: -

- i) Universal testing machine.
- ii) Shear test attachment.
- iii) Specimens.

7.3 DIAGRAM: -

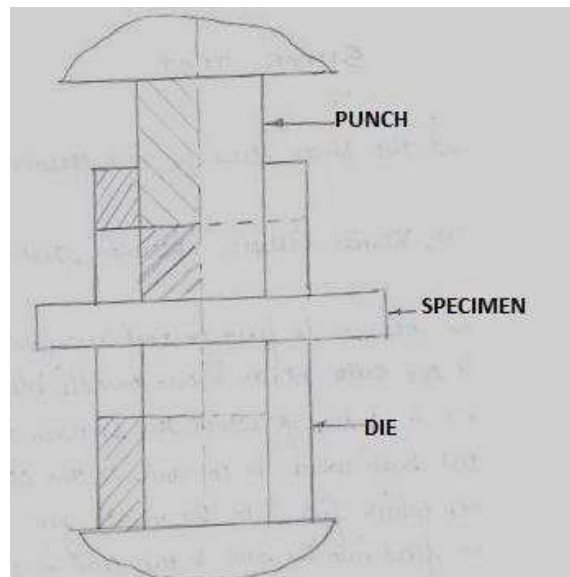

THEORY: -

Place the shear test attachment on the lower table, this attachment consists of cutter. The specimen is inserted in shear test attachment & lift the lower table so that the zero is adjusted, then apply the load such that the specimen breaks in two or three pieces. If the specimen breaks in two pieces then it will be in single shear & if it breaks in three pieces then it will be in double shear.

PROCEDURE:

1. Insert the specimen in position and grip one end of the attachment in the upper portion and one end in the lower portion.
2. Switch on the main switch of universal testing machine machine
3. The drag indicator in contact with the main indicator.
4. Select the suitable range of loads and space the corresponding weight in the pendulum and balance it if necessary with the help of small balancing weights.
5. Operate (push) buttons for driving the motor to drive the pump.
6. Gradually move the head control level in left-hand direction till the specimen shears.
7. Down the load at which the specimen shears.
8. Stop the machine and remove the specimen

Repeat the experiment with other specimens.

OBSERVATIONS: -

Diameter of the Rod, $D = \dots$ mm

Cross-section area of the Rod (in double shear) = $2 \times \pi/4 \times d^2 = \dots$ mm²

Load taken by the Specimen at the time of failure, $W =$

N Strength of rod against Shearing = $f \times 2 \times \pi/4 \times d^2$

$$f = W / 2 \cdot \pi/4 \cdot d^2 \text{ N/mm}$$

RESULT:

The Shear strength of mild steel specimen is found to be = N/mm²

PRECAUTIONS: -

1. The measuring range should not be changed at any stage during the test.
2. The inner diameter of the hole in the shear stress attachment should be slightly greater than that of the specimen.
3. Measure the diameter of the specimen accurately.

Experiment No: 10

VERIFICATION OF MAXWELL'S RECIPROCAL THEOREM ON BEAMS

AIM:

To find young's modulus of the material of the given beam by conducting bending test on simply supported beam using Maxwell's law of reciprocal deflections.

APPARATUS:

Beam supports, Loading yoke, Slotted weight hanger, Slotted weights, Dial gauge, Dial gauge stand, Scale & Vernier callipers

FORMULA:

For a simply supported beam with concentrated load at mid-span the formulae of deflection is as follows:

$$\delta = \frac{11}{768 EI} WL^3$$

PROCEDURE:

1. The breadth and depth of the beam along the span is measured and average values are taken.
2. The load is applied in increments and the corresponding deflections with the help of dial gauge are measured.
3. Precautions are to be taken to keep the dial gauge in correct position to measure the desired deflection.
4. The deflections corresponding to various loads for each case are tabulated.
5. The beam is placed horizontally and in the first case, the loads are acted in the middle and dial gauge is placed at $1/4^{\text{th}}$ of the beam and loads are added slowly and according to the load, the readings are noted. Similarly note down the deflections while unloading.
6. In the second case load is placed at $1/4^{\text{th}}$ of the beam and dial gauge at the center and the readings are noted similar to the first case.

<u>S</u>	<u>Parameters of set-up</u>	<u>Value</u>
1	Width of the beam (rectangle) cross-section, b mm	
2	Depth of the beam (rectangle) cross-section, d mm	
3	Moment of inertia , $bd^3/12$	

OBSERVATIONS:

Table 2:

S No	Load applied(W)		Deflection in mm		Average	LC x Avg.	Young's Modulus (E) N/mm ²
	Kg	N	Loading	Unloading			
Case (i)							
1							
2							
3							
4							
5							
6							
7							
Case (ii)							
1							
2							
3							
4							
5							
6							
7							

Table 3:

S.No	Load(W) N	Avg. 1	Avg. 2	Average of 1&2(z)	Young's Modulus	% Error (z-(x or
1						
2						
3						
4						
5						
6						

Case (i):

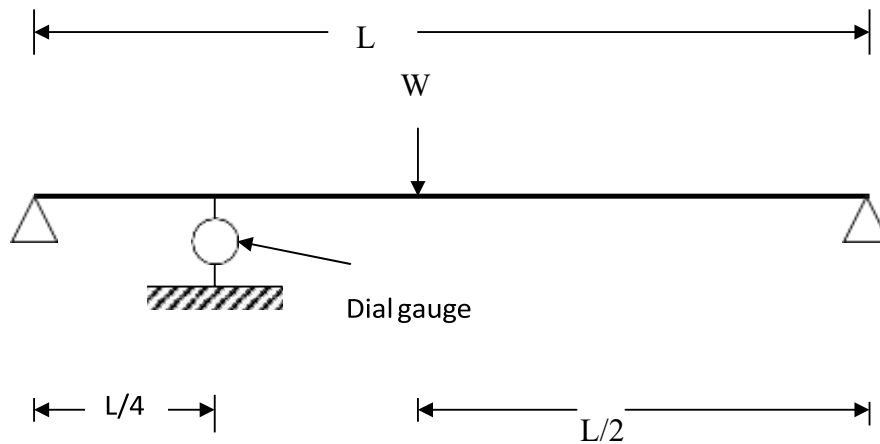

Case (ii):

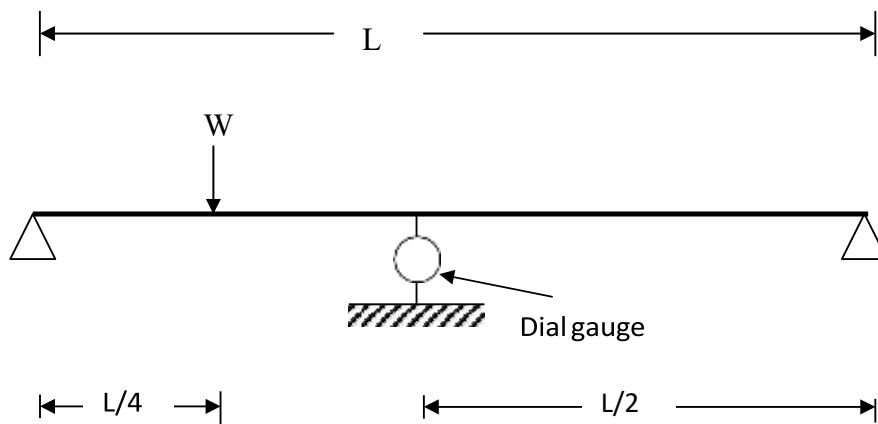

CALCULATIONS:

Moment of inertia (I) = _____ mm⁴

Young's Modulus (E) = $(11/768) * (W/\delta) (L^3/I)$

RESULT: The Young's modulus of steel by Maxwell's reciprocal theorem is:
The percentage error is:

GRAPHS TO BE DRAWN:

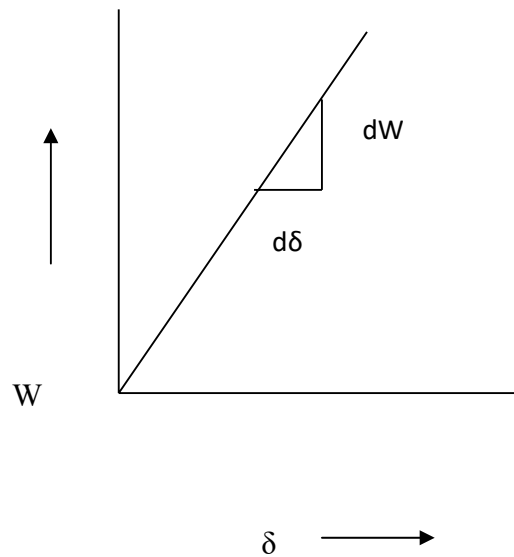

Experiment No - 11

USE OF ELECTRICAL RESISTANCE STRAIN GAUGE

Aim:

To measure the stress & strain using strain gauges mounted on cantilever beam.

Apparatus used:

- 1 Strain gauge Kit,
- 2 cantilever beam weights,
- 3 Multimeter.

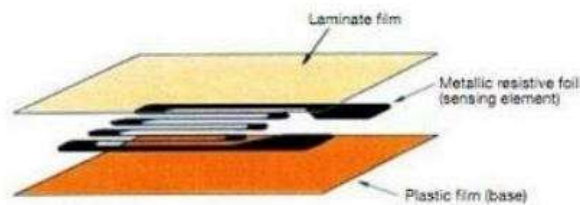

Fig: Strain Gauge

Procedure:

1. Arrange the cantilever beam, ammeter and voltmeter as shown in figure.
2. After this, put the weight on the rod of cantilever beam.
3. Measure the digital display reading for a particular weight.
4. Measure the value of ammeter (along) and voltmeter reading (micro-volt)
5. Increase the strength of weight.
6. Repeat the steps for increased weight.
7. Measure all dimensions of scale of cantilever.
8. Plot a graph between $\Delta R/R_0$ and strain (ϵ).
9. Find Gauge Factor (GF) by finding the inverse of the slope i.e. $\frac{\epsilon}{\Delta R/R_0}$
10. Mark on $\frac{\Delta R}{R_0}$ the graph and use Gauge Factor to find strain.

Observations & Calculations:

S.No	Loads (gms)	Resistance			$\frac{\Delta R}{R_o}$	Strain
		R_o	R_f	$\Delta R = R_f - R_o$		
1.						
2.						
3.						
4.						
5.						
6.						
7.						

Strain ϵ (Theoretical) = $\frac{\Delta l}{l} = \frac{6PL}{Ebt^2}$ for cantilever type elastic member

$$\epsilon(\text{Experimental}) = \frac{\frac{\Delta R}{R_o}}{\text{Gauge Factor (GF)}}$$

Modulus of Elasticity $E = \text{Stress}/\text{Strain}$

Strain = $E \times \text{strain} = E \times e$

Depending upon the beam used in apparatus force stress and strain values varies accordingly with simply supported or cantilever beam terminology.

Experiment No: 12

CONTINUOUS BEAM - DEFLECTION TEST

AIM:

To find the young's modulus of the given structural material (mild steel or wood) by measuring deflection of Continuous beam.

APPARATUS:

Beam supports, loading yoke, Slotted weight hanger, Slotted weights, Dial gauge, Dial gauge stand, Scale & Vernier callipers.

THEORY:

Consider the following loading case as a two span continues beam of Uniform flexural rigidity EI. It is loaded at half of each span from end supports and deflection is measured at $1/4^{\text{th}}$ of span from right end support.

$$\text{Deflection } (\delta) \text{ at F} = (43/6144) * (WL^3/EI)$$

Where δ = Deflection

W= Load.

L= span

E= Young's Modulus

I = Moment of inertia of the beam = $(1/12) * (bd^3)$

PROCEDURE:

A beam of known cross-section (rectangular shape with width "b" and depth "d") and length "L" is simply supported at two ends and at the center (at A,C &B).

Equal loads W are applied at half of each span (at D & E) as shown in the figure

(1) In six increments. The deflection at F is correlated graphically to the load applied and the Young's Modulus is determined.

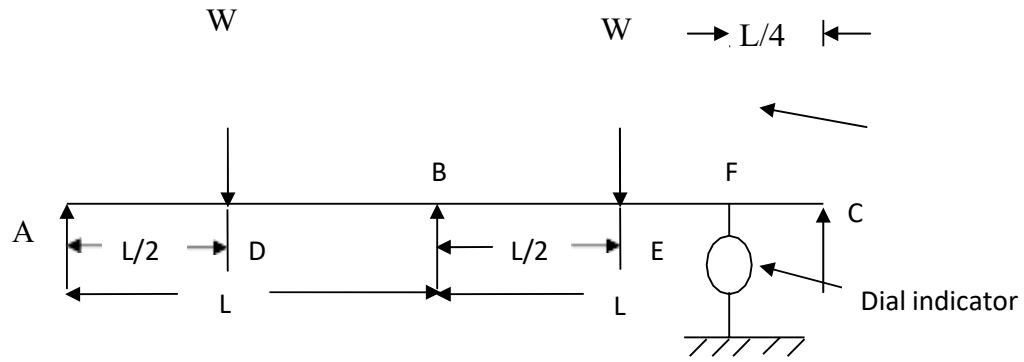

Figure.1: Continuous Beam Deflection.

OBSERVATIONS:

<u>SL.No</u>	<u>Parameters for set-up-1</u>	<u>Value</u>
1	Width of the beam (rectangular) cross-section, b mm	
2	Depth of the beam (rectangular) cross-section, d mm	
3	Length of the beam between supports , L, mm	
4	Location of the load W from left support (L/2) mm	
5	Location of the deflection point from right support (L/4) mm	

CALCULATION OF CONSTANTS:

Moment of inertia (I) =

Young's Modulus (E) =

$$(43/6144) * (W/\delta) * (L^3/I)$$

TABULAR COLUMN:

Sl No	Load applied (W)		Deflection in mm		Average	Deflection LC x Avg.	Young's Modulus (E)
	Kg	N	loading	unloading			N/mm ²
Quarter span (Steel Specimen)							

RESULT:

Young's Modulus of STEEL from the deflections on a two span continuous beam is:

_____ N/mm²

GRAPHS TO BE DRAWN:

Deflection (δ) vs. Load (W)

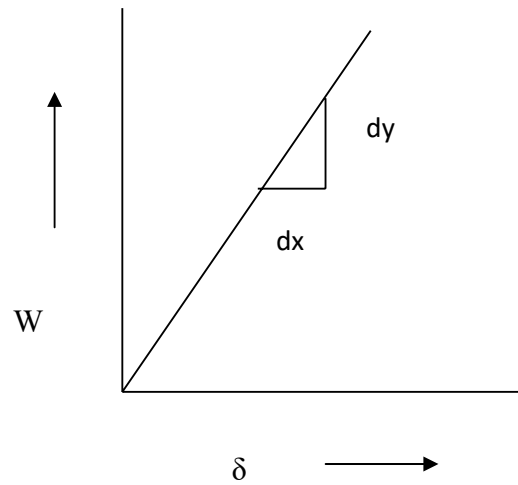

CONTINUOUS BEAM SETUP





KG REDDY

College of Engineering
& Technology

AN AUTONOMOUS INSTITUTION



CHILKUR VILLAGE, MOINABAD MANDAL,
HYDERABAD - 501504, TELANGANA.
Ph. : 94907 73777

KGR.AC.IN

EAMCET/ECET/ICET CODE - KGRH